

Before

YOU BUY YOUR

**Water Dispenser
or Water Filters
Read this E-book**



By Stephen Steineck

The Information You Need to Make the Right Decision

This booklet will walk you through what you need to know to buy the right water cooler for your unique situation. If you are looking to buy a water dispenser that will give you years of service, provide high quality drinking water, with features that suit YOUR needs and desires, then you have the right information here in front of you.

This booklet contains important, factual information based on Abbey Spring's two decades in the "bottleless" (or filtered) water industry. Our goal is to help you avoid purchasing equipment that does not last, does not perform as advertised, or is simply not a good match for your circumstance.



PWC1500S

*The human brain is about 75% water,
our muscles are about 60% water.
Clean water is essential for mental
and physical health.*

“If only I’d known before I bought.”

Abbey Spring wants to help you avoid the “if only I’d known before I bought” syndrome. Abbey Spring is deeply committed to its customers and makes every effort to ensure they get the right water dispenser or cooler to fit their needs, whether for home or office.

Reading this booklet (or having a twenty-minute conversation with the owner of Abbey Spring, Stephen Steineck, a 20 year water dispenser industry professional), will go a long way to helping you make your purchase the right one and a lasting one.

This booklet is our gift to you, and represents our sincere effort to assist you by providing you the most relevant and important information to help you purchase the right office water cooler for your needs without compromise or confusion.



PWC2000 ex

One rule of thumb states that for every 50 pounds of body weight you carry, drink one quart of filtered water per day.

What You Need to Know: Your Most Important Considerations

1 Understand the difference: bottleless water coolers versus traditional bottled water coolers.

Bottleless water coolers take up less space, are less expensive to operate in most cases and will provide equal or higher quality drinking water than their “bottled” competitors. Bottleless water coolers are superior to bottled water coolers in every way except one—they cannot operate without plumbing. There is only one good reason to be lifting five gallon bottles of water, and that is that plumbing is not available at your site.



PWC2000

There is only one good reason to be lifting five gallon bottles of water: plumbing is not available at your site.

Bottleless Advantage

Water Quality

Bottled water is usually purified tap water. All Aquifina and Desani water, and most five-gallon bottles, are purified tap water. At Abbey Spring our reverse osmosis filtration system provides the same filtration technology as bottled water companies—without the delivery fees. You get as good or better water quality at a lower cost to you and the environment.

Labor

More and more, businesses are becoming aware, often through litigation, of back injury risks to employees who engage in heavy lifting. In addition to the threat of employee injury, consumers may also shy away from bottled water due to the delivery schedules, maintenance, and storage of the bottles themselves. Simply put, many people would rather not hassle with the lifting up or the pickup and delivery of water bottles, nor do they have the extra space to store the bottles once they arrive.



For more information go to

http://abbeyspring.com/worry_free_water-info.html

and read the entire article on worry-free water.

2 The question of water quality

TWO EXCELLENT CHOICES

Choice A:

Standard carbon filtration

Standard carbon filtration filters water down to 10 microns. This process eliminates the big offenders in city water, i.e. chlorine and ammonia, which is used to sanitize city water—without the storage and sanitation problems associated with the handling of

big, heavy jugs of water. Standard carbon filtration is an excellent choice where the water going into the water cooler is of pretty good quality. You can opt for a one micron carbon block filter that also eliminates cysts and lead in water if this is a concern for you.



FP2 — A Standard Filtration System

For more information go to http://abbeyspring.com/activated_carbon-info.html and read the entire article on standard carbon filtration.

Bottleless Advantage

Bacteria: The Enemy of Water Quality

Traditional water coolers require changing the water bottles on a regular basis. Though the water inside the bottles is usually clean and pure, the outside of the bottle (particularly the neck) can become contaminated through handling. Everyone who handles that bottle, from the factory to you, has picked it up by its neck. When the water bottle is placed on the cooler, the neck sits inside the cooler's reservoir, inadvertently introducing bacteria, unless you sanitize it with some disinfectant first. Additionally, as water is consumed, the air drawn in from around the bottle introduces airborne contaminants to the drinking water.

In time, the bacteria and the airborne contaminants will continue to increase and collect unless the customer regularly cleans and sanitizes the water cooler. In a study conducted at Boston's Tufts University, bacteria counts from ten water coolers on campus were found to be "four times the 500 organism limit the government recommends." With increased bacteria counts, users increase their risk of contracting gastroenteritis, an illness characterized by vomiting and diarrhea.

For more information go to http://abbeyspring.com/worry_free_water-info.html and read the entire article on worry-free water.

2 The question of water quality

TWO EXCELLENT CHOICES

Choice B:

Reverse Osmosis

If you are in an area with questionable water quality or with high total dissolved solids, or if you simply want the cleanest, most pure drinking water experience you can get, then reverse osmosis filtration would be a good choice for you. Keep in mind that "RO" requires a return line for water drainage and filters water more slowly than standard filtration. If you want to consider reverse osmosis then a conversation with our water experts is recommended to make sure you get the proper water cooler that will compensate for the slower water production. The membrane/filter, that makes this a reverse osmosis system, is self-cleaning and will last about three years or longer before it needs to be replaced. As water is being filtered to drink, the membrane is cleaning itself of the impurities it has removed from the water and sends that waste water down the drain. All Desani and Aquafina bottled water is made in

this same way, i.e. city water that is purified by the reverse osmosis process.

The two pre-filters on this system still need to be changed every six to twelve months.

For more information go to <http://abbeyspring.com/reverse-osmosis-info.html> and read the entire article on reverse osmosis filtration.



Reverse Osmosis Filtration

Decision Point

How much water in a day you use?

This is a decision point that can have an effect on the type of filtration you select or the capacity of a water cooler. Volume use may steer you to certain coolers with larger hot and/or cold tanks, which may affect overall space considerations. The point of this book is to make you aware of the decision points that need consideration, not to be so detailed that you become an expert on water filtration and coolers.

A good rule of thumb on volume:

Low use	1-5 users	1 to 4 gallons per day
Medium use	6-20 users	5 to 8 gallons per day
Heavy use	15 to 60 users	8 to 20 gallons per day
Ultra heavy use	30 to 70 users	15+ gallons per day

Beyond this a second unit may be needed.

Note: Some people and/or groups are naturally higher or lower users of water. This is a discussion point that needs to be addressed and can be discussed on the phone with Stephen Steineck, owner of Abbey Spring.

The Environmental Protection Agency lists over 700 chemicals in our drinking water, and that includes “clean” sources such as wells and springs.

3 Consider the features of the cooler Do you need:

A. Hot water?

All our coolers but one (PWC1010) have hot water capability, but the hot tank can be turned off on all models if there are other features the cooler has that you want.

B. Extra distance between faucet and drip tray?

Most of the coolers have about 7 to 7.5 inches of space between faucets and drip tray. Our PWC3500, however, has a full 12.5 inches.

C. Re-boil option for making the hot water hotter?

The reboil function on the PWC2000 will raise the standard hot temperature another 10 to 15 degrees.

D. Extra refrigeration zone?

If you want a place to chill cans of soda the PWC1000RF is what you need.



PWC1000RF



E. In tank sanitation?

The coolers with a room temperature tank are worth having this feature/option installed. Because the room temp tank is not refrigerated, prevention of bacterial buildup is important. If you prefer not to have in-tank sanitation, then a regular cleaning of the room temp tank is suggested once per year. There are two ways in-tank sanitation is accomplished, ozone or UV.

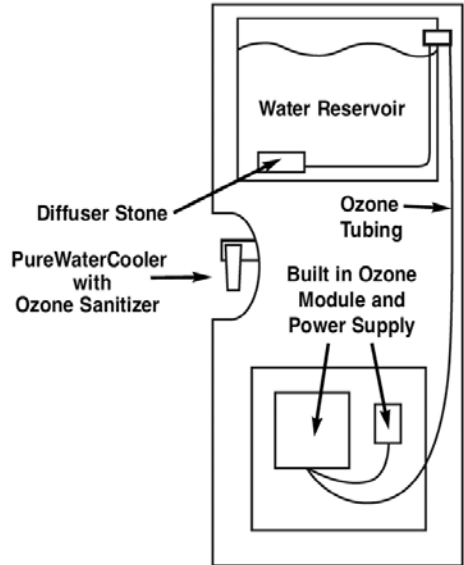

F. UV as part of filtration?

In circumstances where there is special concern for not having any chance of water born microbes in the drinking water, this would be a consideration. This comes in to play mostly with the very young, the elderly, or immune-compromised individuals such as those on chemotherapy. City water is generally very sanitary to begin with, but sometimes this extra measure is necessary or prudent. Well water would be a very good candidate for UV sanitation in the filter stream.

G. Paper cup holder?

This is an easy add-on and can be ordered at the time of your purchase.

According to Dr. John R. Lee, dehydration can cause an imbalance of minerals which can affect your hormone balance.

4 Consider the quality of your filter, cooler, and distributor

A. The question of filter quality

Not all carbon water filters produce healthy water! Some carbon filters made overseas have been found to contain lead. Note: Abbey Spring sells only high quality filters either tested by independent laboratories (like NSF) or supplied by manufacturers with known quality control in the manufacturing processes.



One Micron Carbon Filter

B. Time on the market—a good measure of cooler quality

Water delivery and filtration are processes that should happen without a problem. Some water cooler systems have been on the market for a very short time and may have design flaws that cause failure. Our coolers have been on the market for 8 years or longer, have stood the test of time, and are manufactured in the USA.

If you want to suppress your appetite between meals drinking water can help.

C. Selecting a distributor

Your distributor is a bridge between what manufacturers offer in the market place and you and your needs. Choose a distributor who has demonstrated wisdom in bringing you the best of what the market can offer and fitting it to

your needs. Things work out best when you buy your office water cooler from a distributor who has built a relationship with the manufacturers over a long period of time.

So far we have discussed the four major considerations you need to be aware of to increase your chances of acquiring the right water filtration system for you. Now we'll discuss the next most important points in choosing a water cooler.

Low level dehydration symptoms include: stomach ache, headache, joint pain, body aches, back pain, constipation, fatigue, inability to concentrate and confusion.

OK, so you think you know which water cooler system you want. That's great! But let's explore the final details that will help ensure you have all the facts and information you need before making your final decision.

What about water quality going into your cooler and cooler maintenance and other water cooler considerations:

A. What water source do you have?

- City water or mutual systems
- Well water/country water
- Your region's overall water quality



PWC 400 Counter Top Model

The best way to slow water retention is by drinking more water because when your body is dehydrated, it hangs onto more water than it needs.

Decision Point

In some cases, water quality can drive decision-making just as much as personal preference. We always recommend reverse osmosis for well water because of the unprocessed or minimally processed nature of well water. Whether this is necessary for city water usually depends on the amount of total dissolved solids (TDS) in the water.

This consideration is not so much for health reasons, but because TDS can affect the taste of water, only reverse osmosis reduces the dissolved solids enough to produce good tasting water.

We have found in over 20 years in this business that 90% or more of our customers on city/municipal water systems get a very good tasting water from standard filtration. If you have well water and do not want to have reverse osmosis, then adding UV to the filtration stream would be a good choice.

A first-rate water filtration system is the best way to proactively monitor and ensure the quality and safety of your drinking water.

B. Maintenance demands

1. Internal tanks

All water coolers need maintenance, bottled coolers as well as bottleless. This is especially true when your water cooler has a room temperature tank. Filters also need to be changed regularly. Both of these considerations are important to maintain sanitary conditions in the water stream.

2. In-tank sanitation devices

Either UV or ozone can be used to keep internal tanks sanitary automatically. If these techniques are not used, then a regular inspection and cleaning of the internal tanks is required at least once per year.

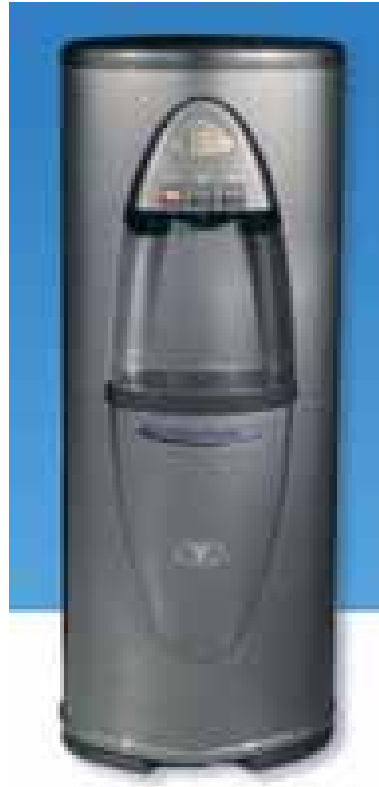

The PWC 3500 comes with a 3 gallon internal holding tank

Chlorine is used in drinking water to kill microorganisms that can cause severe illness. While this is a benefit, it comes at a cost!

If you drink unfiltered city water with chlorine in it you will kill many of the beneficial microorganisms in your digestive tract that you need to stay healthy. Additionally, the by-products that result from the chlorination of water, such as trihalomethanes, are actually a larger concern than the chlorine itself. These by-products don't break down easily and tend to accumulate in the body faster than our detoxification system can handle. They have been linked to cancer, are known to damage the heart, lungs, kidneys, and nervous system, and are as lethal as chlorine to the beneficial bacteria in the intestines that are crucial to immunity and digestion.

3. How often should filters be changed?

The rule we have followed for 18 years in the filtration industry is to change filters every 6 to 12 months. Six months is almost always optimum, especially in commercial/office settings, and twelve months is as long as you want to go no matter what. Changing the filters at one year maximum is based on the following two reasons: filtration media does get saturated/used up, but more importantly, even if the media isn't used up due to low usage, at a year we want to remove the wet, warm, dark media (filters) to prevent possible bacteria buildup inside the filter casings.

The main concern, at one year, is the keeping of sanitary conditions (preventing bacteria growth) through regular filter changes. Secondly, there is a concern over media (filter) saturation when going past a year. Carbon will pull down chlorine (a Volatile Organic Chemical or VOC) a lot longer than it will pull other VOCs like ammonia, Trihalomethanes, and Chloramines. We have followed the stated rule of thumb, changing filters every 6 to 12 months, for the 18 years we have been in the business, and it has served our clients well.



PWC 2000 Filters

All Abbey Spring filters remove chlorine from drinking water.

C. How much space do I need?

Generally an 18" to 24" clear space is needed for most water dispensers, but each water dispenser system will have its own clearance requirements.

1. Dimensions and clear space requirements of coolers that we distribute are given on our web site: see <http://abbeyspring.com/products.html>

2. Breathing room (Clear Space) around cooler (give 4" on back and 2" on sides)

3. Counter top coolers may be the answer if floor space is not available, or if it is too difficult to get the water to the cooler at some distance from the water source.

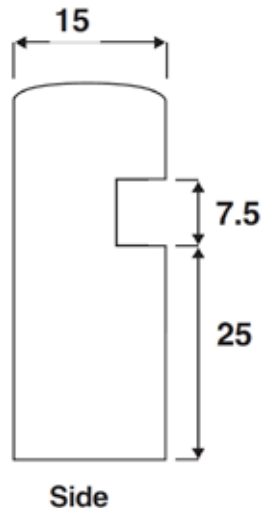
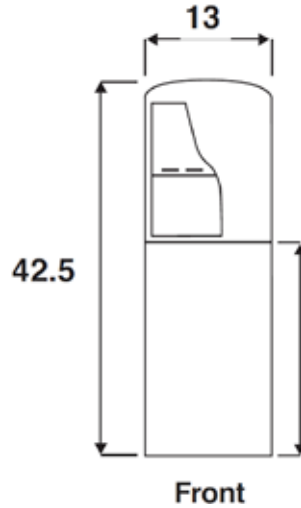

One problem with bottled water is that it usually comes in plastic which can leach harmful chemicals if exposed to heat or sunlight.

D. Do I need a plumber to put it in?

1. Please consult local laws in this issue. Some states, counties and cities have restrictions.
2. Handyman or building engineer or janitor

In many situations you will be able to hire a handyman to install your plumbing line(s) for your water cooler and avoid the expense of a certified plumber. Often the building engineer has installed point of use devices in the building already. Installing a water cooler is no different than plumbed coffee makers or icemakers.

3. Some people can “do it yourself”

While some basic skill is needed to tie into your existing plumbing, it is not too difficult unless you have access issues. An Abbey Spring representative will be able to walk you through how to get your new water cooler up and running.



While a handyman or plumber may be needed for your initial installation all Abbey Spring water coolers are designed for easy care and “fingers only” filter replacement.

Conclusion

It is our hope that after having read this booklet you are now more confident regarding any decision you might make in your water filtration and dispensing system needs.

While Abbey Spring does not claim to be the only distributor on the market able to help you get the right water cooler for your needs, we are one of the top choices based on our twenty plus year of experience, thousands of happy customers worldwide, and the many positive client testimonials we continually receive.

If you still want more help, we want to encourage you to call us and receive the final pieces of information you need to make the right purchase that will serve you for a long time to come.

Call Abbey Spring today. You will have access to Abbey Spring president Mr. Stephen Steineck who is one of the most knowledgeable water experts in the point of use, water cooler, water dispenser, and water filter industry today.

To Your Health!

Stephen Steineck, Owner



ABBAY SPRING

Filtration systems that return your water to its natural purity

Call **ABBAY SPRING**

for expert help with the purchase of your office
or personal water cooler and filtration system.

Abbey Spring
P.O. Box 8598
Santa Rosa, CA 95407

(707) 545-0278 (local)
(800) 844-0448 (toll free)
Fax: (707) 542-3117

Hours: 8am – 4pm Monday – Friday Pacific time

email: s.steineck@abbeyspring.com



ABBKEY SPRING

Quick Checklist

1. Is plumbing accessible to where you want your water cooler to stand? The quarter inch feed water tubing can be run 100 feet or more if necessary. If no, then you need bottled water, if yes, a better solution is filtered water.
2. What type of water filtration do you want? Standard filtration or reverse osmosis? Available space and your feed water quality play a role here.
3. How much water do you use? See chart on page 9.
4. What features do you require? Will you make tea and soup, or do you just need cold and room temperature water?
5. Consider the quality of your filter's manufacturing process. Some filters have been found to contain lead.

Filtration systems that return your water to its natural purity

Checklist (continued)

6. Consider the quality of your cooler.
Will your unit stand the test of time?
7. Consider the quality of your distributor.
How long has your distributor been in business?
How much expertise does he or she have? Is the person you are talking to a water expert or just a sales person? Will they be there if you need help?
8. Regular maintenance.
It pays to know this piece to the puzzle before you buy.
9. How much space do you need for the unit that fits your needs?
10. Have you double checked your needs with a true water expert?

A \$50 per month for bottled water service

\$50/month is a low usage situation. For 10 years this amount equals \$6000. Plus you have lifted 38400 lbs of water, kept the trucks on the road, and stored 960 bottles of water. You will have had to sanitize those 960 bottles too.

The product cost for the 5 gallons of water in that bottle is less than a penny! You pay \$5 or more for a penny of water.

B \$38 per month to rent or lease a bottleless water system

Low estimate is \$38/month per cooler in your business.

In 10 years you will have spent \$4560 per cooler.

You also may pay extra for filter changes (labor and filter cost) You also may have to pay for installation.

You also may be committed to a long term lease agreement. Abbey Spring used to have a rental program. It was hugely profitable for us as you can see in this comparison. You may save money over bottled water by renting but you could save a bundle more by owning your own system.

C \$10 per month to own your own bottleless water cooler system from Abbey Spring

In ten years you will have spent about \$1200, including purchase price, shipping of cooler, installation cost and filter replacement cost including shipping.

You will not have lifted any pounds of water, nor stored a single bottle, and you will have greatly reduced your contribution to delivery trucks racing around your city every week.



Which price would you rather pay for your drinking water needs?

A

\$50

per month

B

\$38

per month

C

\$10

per month

With option "C" you will not sanitize a single bottle. You will know exactly how your water is filtered and when the filters are changed. Abbey Spring will help you remember when to change the filters and will keep detailed records of all filter changes for you. Abbey Spring coolers are designed to be customer/owner serviced. No tools required, just finger tips for a filter change.

Did you know that entire cities, big and small, are changing over to bottleless water coolers?

Join the thousands of others that have turned to Abbey Spring for their water solution. Join companies like the **J. Paul Getty Museum, the USAF, US Army, Kaiser Permanente, US Navy, Black and Decker, Rite Aid, Best Western, Hyatt Inns, Susan G. Komen for the Cure, AT&T, Comfort Inn, Carnegie Institution, DFW Airport, Dupont, Ford Motor Company, Hilton Inn, Johns Manville, Residence Inns, US Coastguard, USPS, and many other foundations, city and county governments, medical offices and hospitals.** The math works for them, let it work for you.



ABBEY SPRING

Filtration systems that return your water to its natural purity

Which price would you rather pay for your drinking water needs?

A

\$50

per month

B

\$38

per month

C

\$10

per month

Find out why this is a real choice for you concerning your drinking water needs. At \$10 per month you can have virtually unlimited pure drinking water from Abbey Spring.

(See details on pages 24 and 25 of this booklet)

Abbey Spring
P.O. Box 8598
Santa Rosa, CA 95407

(707) 545-0278 (local)
(800) 844-0448 (toll free)
Fax: (707) 542-3117

Hours: 8am – 4pm Monday – Friday Pacific time
email: s.steineck@abbeyspring.com